

Ball Joint Housing Data Sheet

BJC Ball Joint Housing

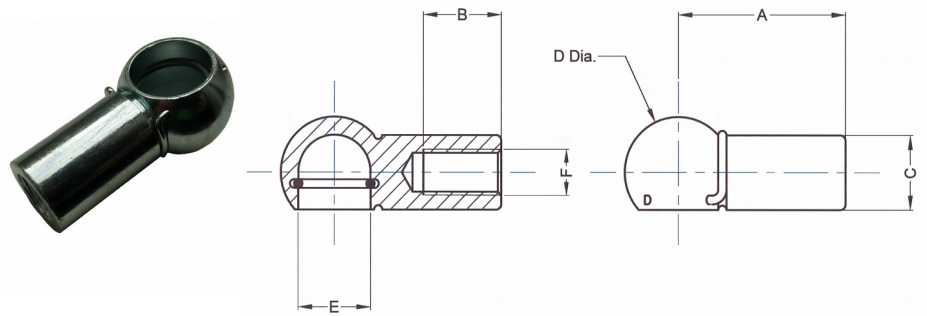

| Part No. | A | B | C | D | E | F | Weight gm. |
|-----------|----|------|----|------|----|----------|------------|
| BJCM05H | 22 | 10.2 | 8 | 12.8 | 8 | M5x0.8 | 13 |
| BJCM0506H | 22 | 10.2 | 8 | 12.8 | 8 | M6x1.0 | 12 |
| BJCM06H | 25 | 11.5 | 10 | 14.8 | 10 | M6x1.0 | 22 |
| BJCM0608H | 25 | 11.5 | 10 | 14.8 | 10 | M8x1.25 | 21 |
| BJCM08H | 30 | 14.0 | 13 | 19.3 | 13 | M8x1.25 | 45 |
| BJCM08H25 | 25 | 10.5 | 13 | 19.3 | 13 | M8x1.25 | 41 |
| BJCM0806H | 30 | 14.0 | 13 | 19.3 | 13 | M6x1.0 | 46 |
| BJCM0810H | 30 | 14.0 | 13 | 19.3 | 13 | M10x1.5 | 44 |
| BJCM10H | 35 | 15.5 | 16 | 24.0 | 16 | M10x1.5 | 86 |
| BJCM12H | 35 | 15.5 | 16 | 24.0 | 16 | M12x1.75 | 84 |
| BJCM14H | 45 | 21.5 | 22 | 30.0 | 19 | M14x2.0 | 125 |
| BJCM14HF | 45 | 21.5 | 22 | 30.0 | 19 | M14x1.5 | 125 |

Material:

Housing AISI 1035 Carbon Steel.

Inner retaining ring and safety clip hard drawn spring steel.

Protective Finish:

Zinc plated and passivated. Inner retaining ring and safety clip are de-embrittled.

Based upon Din Standard 71805.

Internal wire ring and safety clip supplied as standard.

If 303/304 Stainless Steel is required the suffix 'SS' should be added to the part number e.g. BJCM08SSH

If Marine grade 316 Stainless Steel is required the suffix 'SS316' should be added to the part number e.g. BJCM08SSH316.

RollerTek Ltd
47 Southalls Way
Norwich
NR3 4SA
Phone: 01603 926326
E-mail: mark@rollertek.co.uk
Web: www.rollertek.co.uk

Co. Reg. No. 6691519
VAT Reg. No. 944 7714 93